

TECHNICAL SPECIFICATIONS	
PARAMETERS	Value
Motor type	80-4B
Frame size	80
Output power (KW/HP)	0.75/1.0
Rated voltage D/Y-(V)	220/380
Rated Speed (RPM)	1385
Rated current D/Y-(A)	3.4/2
Rated torque (N m)	5.17
Efficiency (%)	77
Power factor (cos phi)	0.76
Starting current/Rated current	3.8
Starting torque/Rated torque	2.3
Breakdown torque/Rated torque	2.4
Moment of inertia (Kg*m2)	0.001424
Weight (Kg)	10
Color	Blue-Ral5001
Body	Aluminium
Stator winding wire material	copper
Rotor winding material	aluminium
Driven end bearing	6204-2Z
Non-driven end bearing	6204-2Z
Insulation class	F
Thermal Class	B
IP درجه حفاظت	54

الکتروموتور (۸۰-۴B) ۲۲۰/۳۸۰ ۵۴۴ ۱۵۰۰-۰.۷۵ MFB ۸۰

فلنج B3

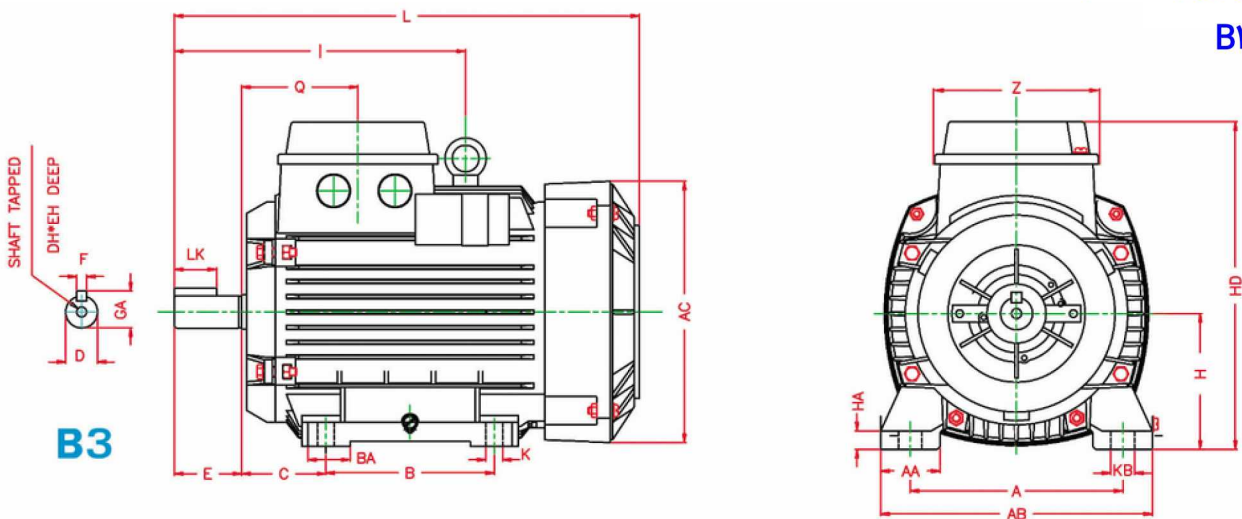

B	BA	K	KB	AB	A	AA	HA	AC	Z	Q	I	L	E	EH	DH	GA	LK	F	D
100	25	10	14	160	125	35	11	156	96	68.5	-	276	40	-	-	21.5	25	6	19

FLANGE SYM (DIN)	FLANGE SYM (IEC)	T	S	P	N	M	LA	AD	HD	H	C
-	-	-	-	-	-	-	-	-	194	80	50

### الکتروموتور (۸۰-۴B) ۲۲۰/۳۸۰ ۵۴F ۱۵۰۰-۷۵ .۸۰MFB

#### فلنج B14

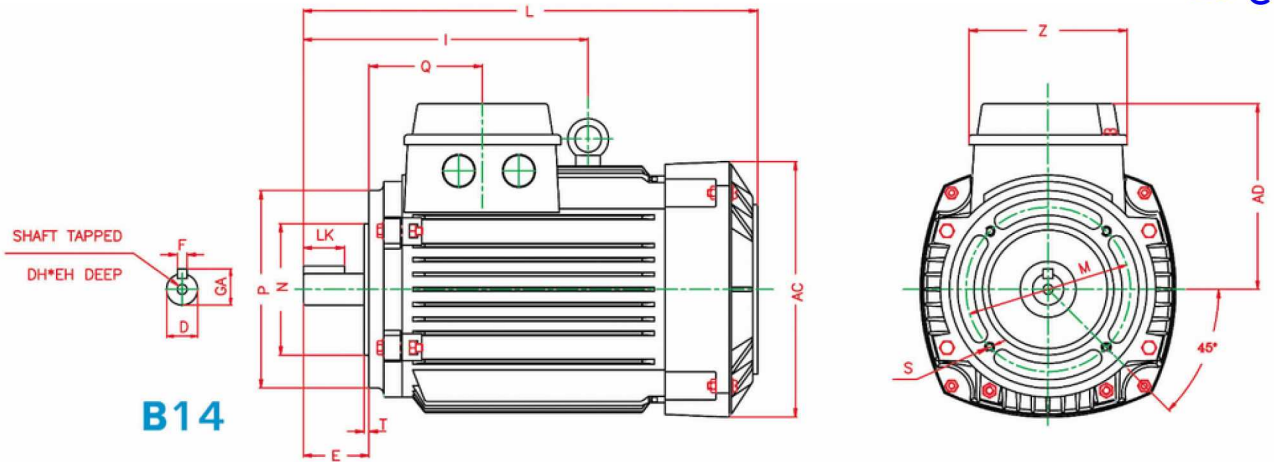

B	BA	K	KB	AB	A	AA	HA	AC	Z	Q	I	L	E	EH	DH	GA	LK	F	D
-	-	-	-	-	-	-	-	156	96	68.5	-	276	40	-	-	21.5	25	6	19

FLANGE SYM (DIN)	FLANGE SYM (IEC)	T	S	P	N	M	LA	AD	HD	H	C
-	C120	FT100	M6	120	80	100	-	114	-	-	-

### الکتروموتور (۸۰-۴B) ۲۳۰/۴۰۰ B5 ۵۵F ۱۵۰۰-۷۵ .۸۰MFB

#### فلنج B5

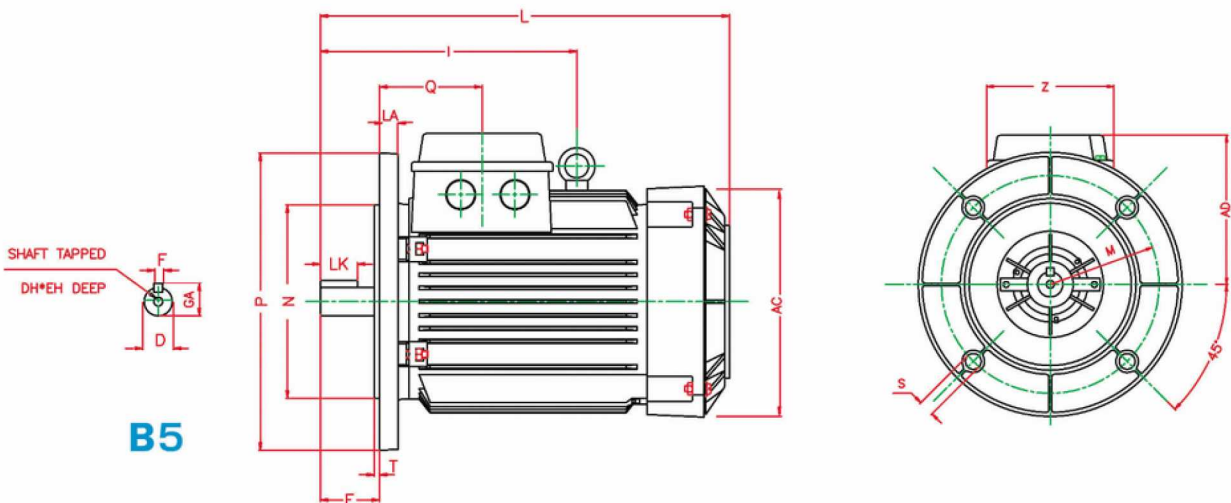

B	BA	K	KB	AB	A	AA	HA	AC	Z	Q	I	L	E	EH	DH	GA	LK	F	D
-	-	-	-	-	-	-	-	156	96	68.5	-	276	40	-	-	21.5	25	6	19

FLANGE SYM (DIN)	FLANGE SYM (IEC)	T	S	P	N	M	LA	AD	HD	H	C
A200	FF165	3.5	12	200	130	165	12	114	-	-	-