

۵,۵ کیلووات - ۷,۵ اسب بخار - ۷۵۰ دور

TECHNICAL SPECIFICATIONS	
PARAMETERS	Value
Motor type	160L8B
Frame size	160L
Output power (KW/HP)	5.5/7.5
Rated Voltage (V)-D/Y	380/660
(RPM) Rated Speed	717
Rated Current (A)-D/Y	12.8/7.4
Torque (N m)	73.97
(%) Efficiency	86.2
(Cos phi) Power Factor	0.78
Starting current / Rated current	4.5
Starting torque / Rated torque	1.6
Breakdown torque / Rated torque	2.3
Moment of inertia (Kg*m2)	0.099187
Weight (Kg)	79
Color	Blue-Ral5001
Body	Aluminium
Stator winding wire material	copper
Rotor winding material	aluminium
Driven end bearing	6309-2Z
Non-driven end bearing	6309-2Z
Insulation Class	F
Thermal Class	B
IP (درجه حفاظت)	54

الکتروموتور (۱۶۰L۸B) ۵FF ۳۸۰/۶۶۰ ۵.۵-۷۵۰ ۱۶۰L۸B

فلنج B۳

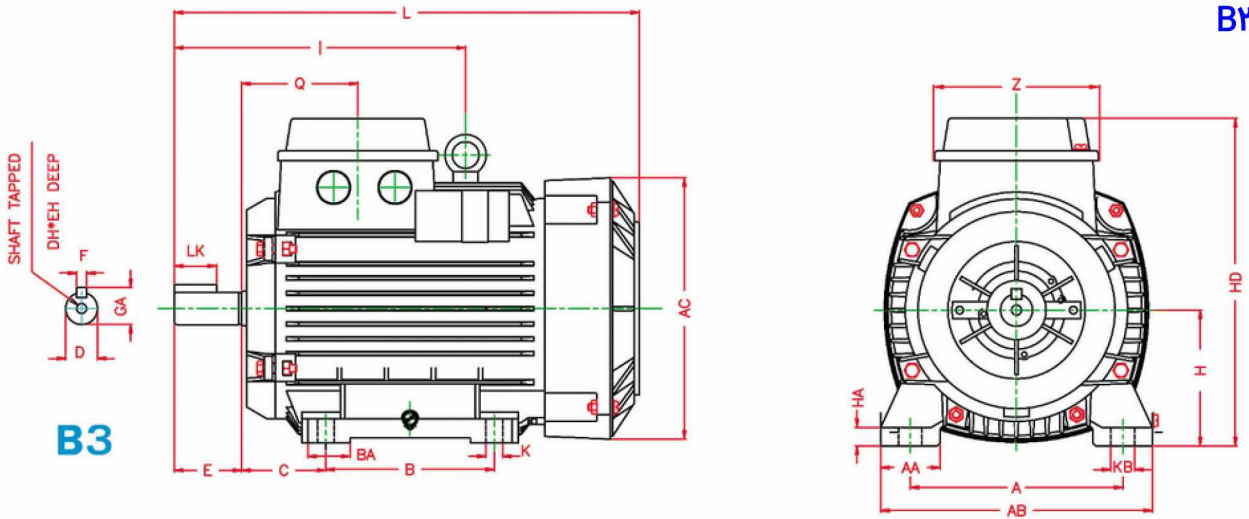

B	BA	K	KB	AB	A	AA	HA	AC	Z	Q	I	L	E	EH	DH	GA	LK	F	D
254	50	15	21	315	254	64	16	303	116	95.5	345	629	110	36	M16	45	80	12	42

X,x	DH*EH	g1	X	FLANGE SYM (DIN)	FLANGE SYM (IEC)	T	S	P	N	M	LA	AD	HD	H	C
				-	-	-	-	-	-	-	-	-	340	160	108

الکتروموتور (۱۶۰L۸B) ۵FF ۳۸۰/۶۶۰ B۵ ۵.۵-۷۵۰ ۱۶۰L۸B

فلنج B۵

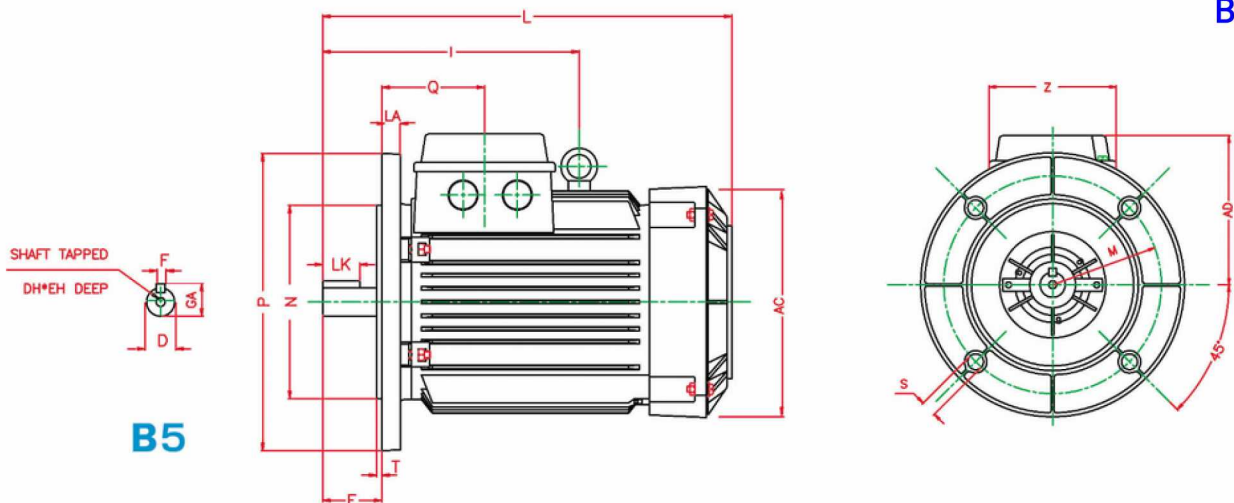

B	BA	K	KB	AB	A	AA	HA	AC	Z	Q	I	L	E	EH	DH	GA	LK	F	D
-	-	-	-	-	-	-	-	303	116	95.5	345	629	110	36	M16	45	80	12	42

X,x	DH*EH	g1	X	FLANGE SYM (DIN)	FLANGE SYM (IEC)	T	S	P	N	M	LA	AD	HD	H	C
				A350	FF300	5	19	350	250	300	13	180	-	-	-