

۷,۵ کیلووات - ۱۰ اسب بخار - ۱۰۰۰ دور

TECHNICAL SPECIFICATIONS	
PARAMETERS	Value
Motor type	160L6A
Frame size	160L
Output power (KW/HP)	7.5/10
Rated voltage D/Y-(V)	380/660
Rated Speed (RPM)	965
Rated current D/Y-(A)	16.5/9.5
Rated torque (N m)	74.22
Efficiency (%)	85
Power factor (cos phi)	0.8
Starting current/Rated current	5.3
Starting torque/Rated torque	2.1
Breakdown torque/Rated torque	2.6
Moment of inertia (Kg*m2)	0.091156
Weight (Kg)	80.8
Color	Blue-RAL5001
Body	Aluminium
Stator winding wire material	copper
Rotor winding material	aluminium
Driven end bearing	6201-2Z
Non-driven end bearing	6201-2Z
Insulation class	F
Thermal Class	B
IP درجه حفاظت	54

الکتروموتور (۱۶۰L۶A) ۵FF ۳۸۰/۶۶۰ ۷.۵-۱۰۰۰

فلنج B۳

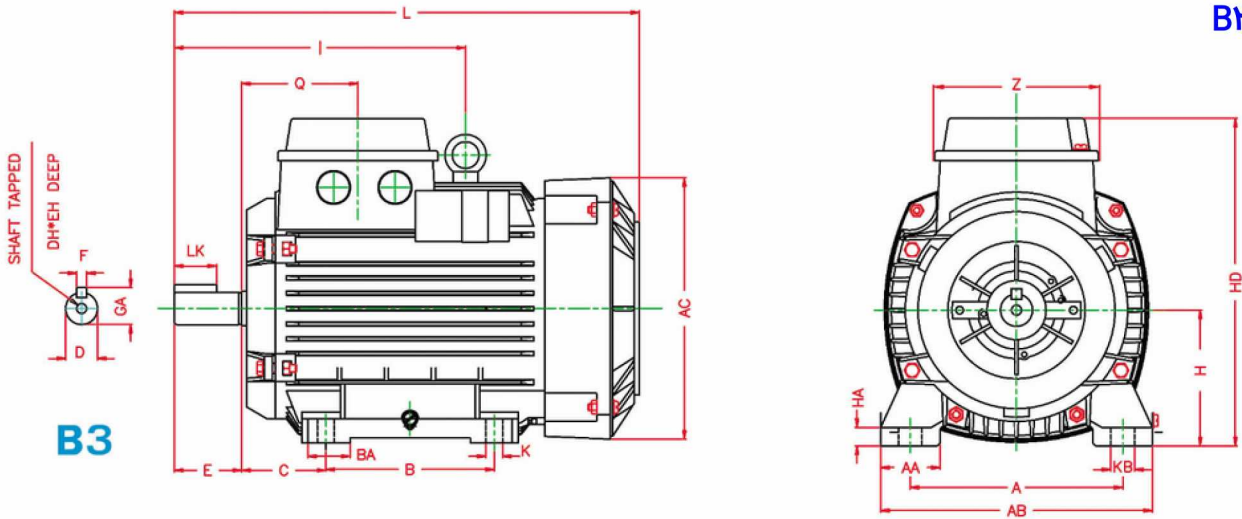

B	BA	K	KB	AB	A	AA	HA	AC	Z	Q	I	L	E	EH	DH	GA	LK	F	D
254	50	15	21	315	254	64	16	303	116	95.5	345	629	110	36	M16	45	80	12	42

X,x	DH*EH	g1	X	FLANGE SYM (DIN)	FLANGE SYM (IEC)	T	S	P	N	M	LA	AD	HD	H	C
				-	-	-	-	-	-	-	-	-	340	160	108

الکتروموتور (۱۶۰L۶A) ۵FF ۳۸۰/۶۶۰ B۵ (۱۶۰L۶A) ۷.۵-۱۰۰۰

فلنج B۵

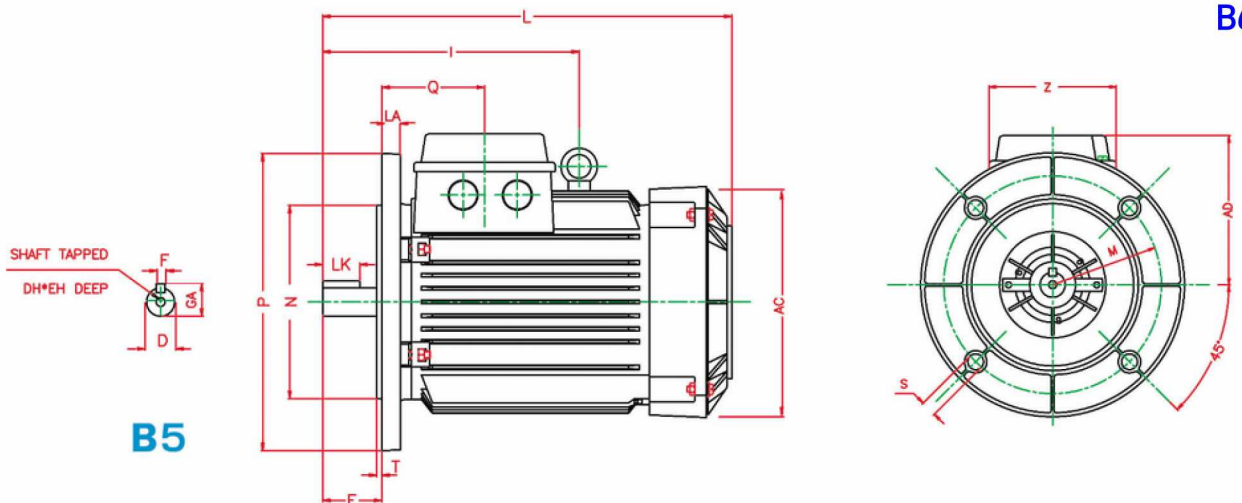

B	BA	K	KB	AB	A	AA	HA	AC	Z	Q	I	L	E	EH	DH	GA	LK	F	D
-	-	-	-	-	-	-	-	303	116	95.5	345	629	110	36	M16	45	80	12	42

X,x	DH*EH	g1	X	FLANGE SYM (DIN)	FLANGE SYM (IEC)	T	S	P	N	M	LA	AD	HD	H	C
				A350	FF300	5	19	350	250	300	13	180	-	-	-