

۱۸,۵ کیلووات - ۲۵ اسب بخار - ۳۰۰۰ دور

TECHNICAL SPECIFICATIONS	
PARAMETERS	Value
Motor type	160LC
Frame size	160L
Output power (KW/HP)	18.5/25
Rated voltage D/Y-(V)	380/660
Rated Speed (RPM)	2940
Rated current D/Y-(A)	35/20.2
Rated torque (N m)	60.1
Efficiency (%)	89.3
Power factor (cos phi)	0.92
Starting current/Rated current	7
Starting torque/Rated torque	3.1
Breakdown torque/Rated torque	3.2
Moment of inertia (Kg*m2)	0.053162
Weight (Kg)	90
Color	Blue-RAL5001
Body	Aluminium
Stator winding wire material	copper
Rotor winding material	aluminium
Driven end bearing	6309-2Z
Non-driven end bearing	6309-2Z
Insulation class	F
Thermal Class	B
IP درجه حفاظت	54

الکتروموتور (۱۶۰LYC) ۱۸.۵-۳۰۰۰ ۵FF ۳۸۰/۶۶۰

فلنج B۳

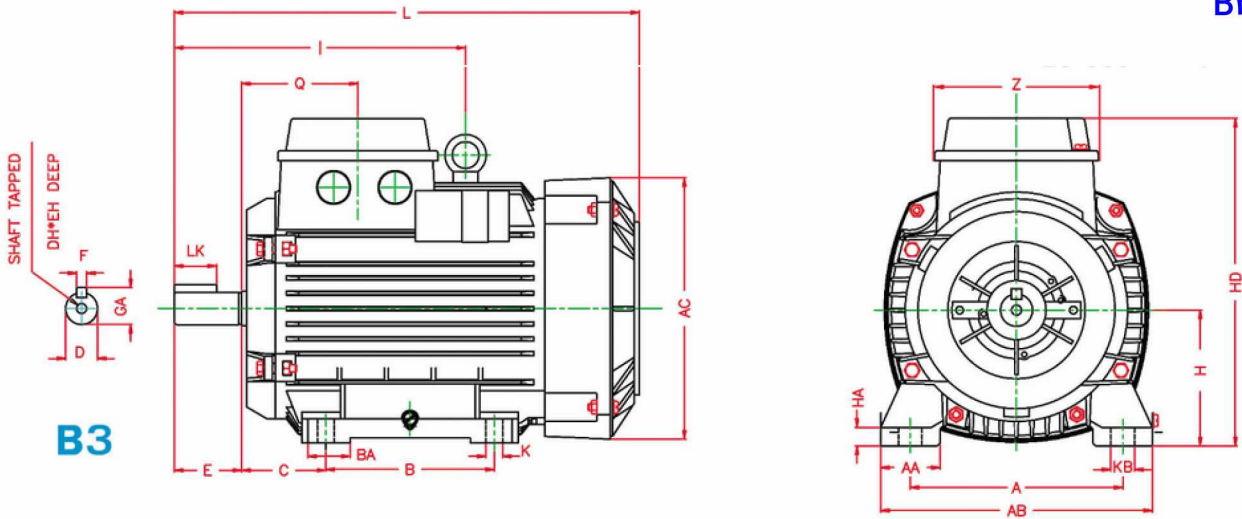

B	BA	K	KB	AB	A	AA	HA	AC	Z	Q	I	L	E	EH	DH	GA	LK	F	D
254	50	15	21	315	254	64	16	303	116	95.5	345	629	110	36	M16	45	80	12	42

X,x	DH*EH	g1	X	FLANGE SYM (DIN)	FLANGE SYM (IEC)	T	S	P	N	M	LA	AD	HD	H	C
				-	-	-	-	-	-	-	-	-	340	160	108

الکتروموتور (۱۶۰LYC) ۱۸.۵-۳۰۰۰ ۵FF ۳۸۰/۶۶۰ B۵

فلنج B۵

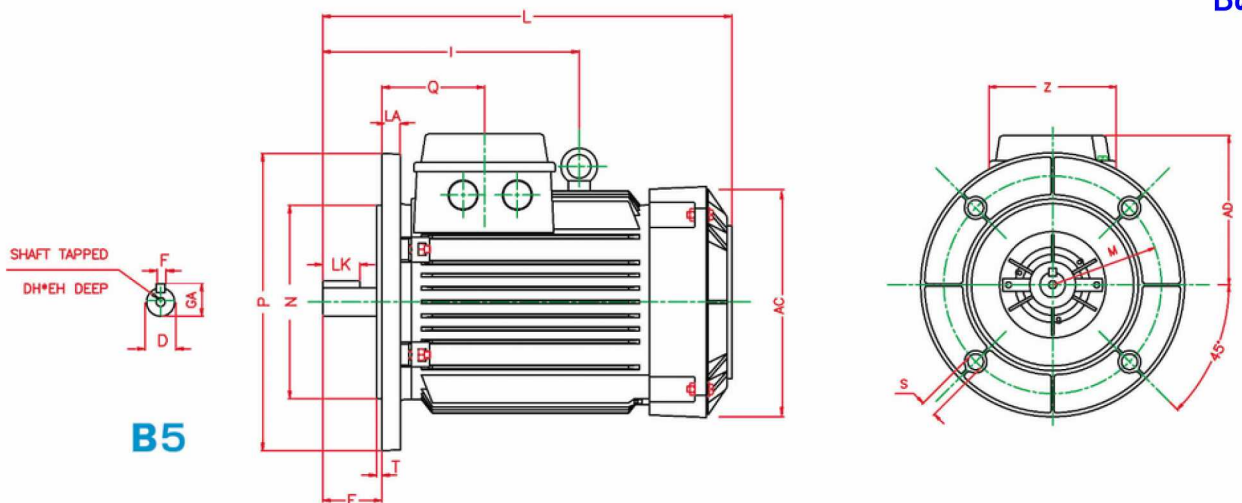

B	BA	K	KB	AB	A	AA	HA	AC	Z	Q	I	L	E	EH	DH	GA	LK	F	D
-	-	-	-	-	-	-	-	303	116	95.5	345	629	110	36	M16	45	80	12	42

X,x	DH*EH	g1	X	FLANGE SYM (DIN)	FLANGE SYM (IEC)	T	S	P	N	M	LA	AD	HD	H	C
				A350	FF300	5	19	350	250	300	13	180	-	-	-