

۳ کیلووات - ۴ اسب بخار - ۷۵۰ دور

TECHNICAL SPECIFICATIONS	
PARAMETERS	Value
Motor type	132M8B
Frame size	132M
Output power (KW/HP)	3/4
Rated Voltage (V)-D/Y	220/380
(RPM) Rated Speed	700
Rated Current (A)-D/Y	13.8/8
(%) Efficiency	80
Torque (N m)	40.93
(Cos phi) Power Factor	0.75
Starting current / Rated current	3.5
Starting torque / Rated torque	2
Breakdown torque / Rated torque	2.3
Moment of inertia (Kg*m <sup>2</sup> )	0.037782
Weight (Kg)	45
Color	Blue-RAL5001
Body	Aluminium
Stator winding wire material	copper
Rotor winding material	aluminium
Driven end bearing	6308-2Z
Non-driven end bearing	6308-2Z
Insulation Class	F
Thermal Class	B
IP (درجه حفاظت)	54

### الکتروموتور (۱۳۲M۸B) ۲۲۰/۳۸۰ ۵FF ۳-۷۵۰ ۱۳۲M۸B

فلنج B۳

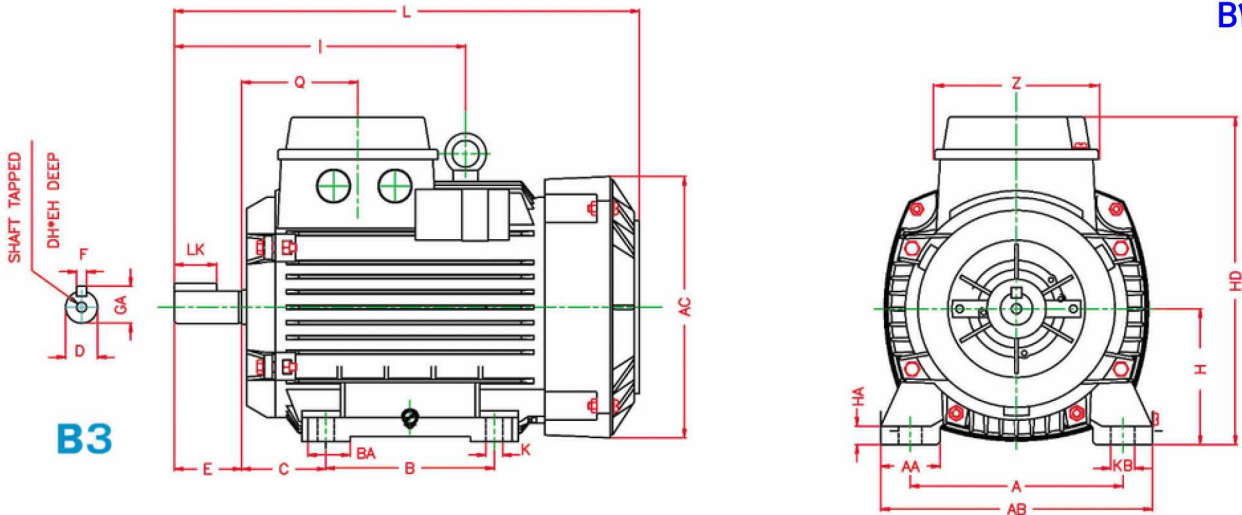

B	BA	K	KB	AB	A	AA	HA	AC	Z	Q	I	L	E	EH	DH	GA	LK	F	D
178	40	12	17	260	216	44	14	255	116	90	258	486	80	28	M12	41	56	10	38

X,x	DH*EH	g1	X	FLANGE SYM (DIN)	FLANGE SYM (IEC)	T	S	P	N	M	LA	AD	HD	H	C
				-	-	-	-	-	-	-	-	-	291	132	89

### الکتروموتور (۱۳۲M۸B) ۲۲۰/۳۸۰ ۵FB ۳-۷۵۰ B۵

فلنج B۵

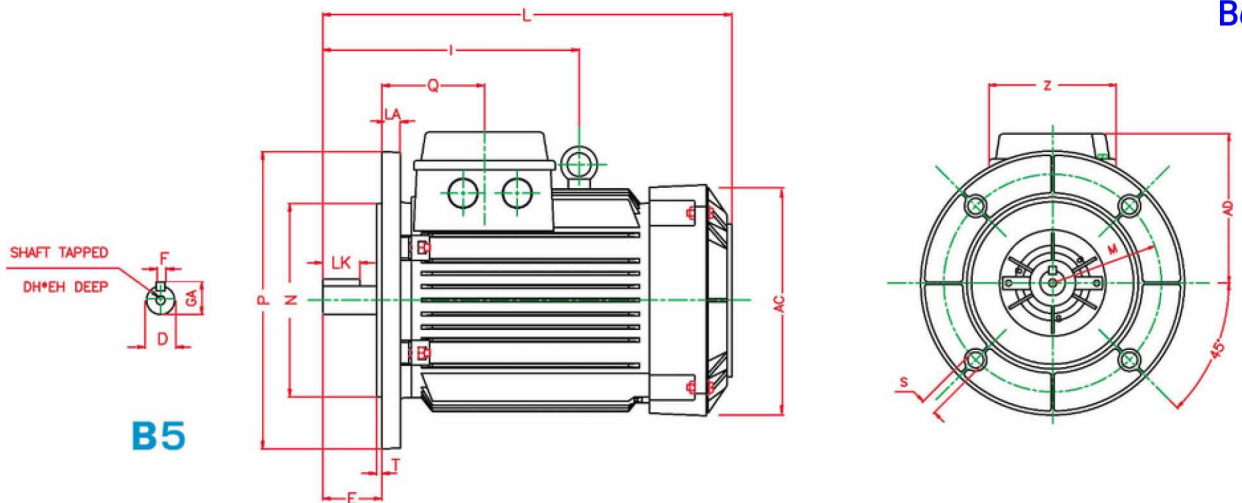

B	BA	K	KB	AB	A	AA	HA	AC	Z	Q	I	L	E	EH	DH	GA	LK	F	D
-	-	-	-	-	-	-	-	255	116	90	258	486	80	28	M12	41	56	10	38

X,x	DH*EH	g1	X	FLANGE SYM (DIN)	FLANGE SYM (IEC)	T	S	P	N	M	LA	AD	HD	H	C
				A300	FF265	4	15	300	230	265	12	159	-	-	-