

۲,۲ کیلووات - ۳ اسب بخار - ۱۰۰۰ دور

TECHNICAL SPECIFICATIONS	
PARAMETERS	Value
Motor type	112M6
Frame size	112M
Output power (KW/HP)	2.2/3.0
Rated voltage D/Y-(V)	220D/380Y
Rated Speed (RPM)	945
Rated current D/Y-(A)	10D/5.8Y
Rated torque (N m)	22.23
Efficiency (%)	82
Power factor (cos phi)	0.72
Starting current/Rated current	4.5
Starting torque/Rated torque	2.6
Breakdown torque/Rated torque	2.5
Moment of inertia (Kg*m2)	0.017553
Weight (Kg)	29.7
Color	Blue-RAL5001
Body	Aluminium
Stator winding wire material	copper
Rotor winding material	aluminium
Driven end bearing	6306-2Z
Non-driven end bearing	6306-2Z
Insulation class	F
Thermal Class	B
IP درجه حفاظت	54

الکتروموتور (۱۱۲M۶) ۲.۲-۱۰۰۰ ۵۴۴ ۲۲۰/۳۸۰

فلنج B۳

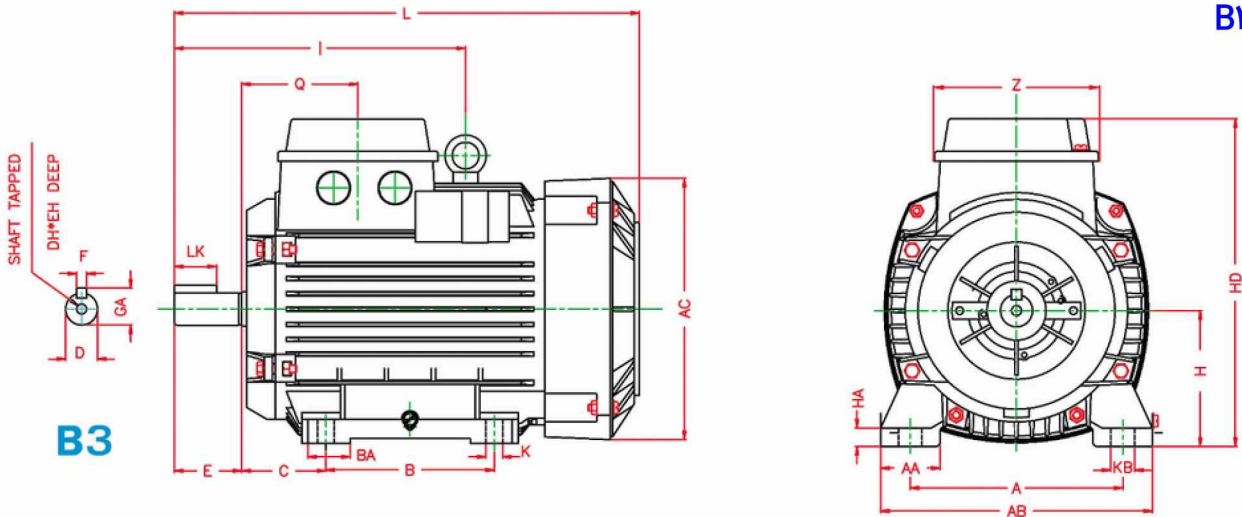

B	BA	K	KB	AB	A	AA	HA	AC	Z	Q	I	L	E	EH	DH	GA	LK	F	D
140	35	12	17	235	190	45	13	217	96	76.5	200	384	60	22	M10	31	40	8	28

X,x	DE*EH	g1	X	FLANGE SYM (DIN)	FLANGE SYM (IEC)	T	S	P	N	M	LA	AD	HD	H	C
				-	-	-	-	-	--	-	-	-	256	112	70

الکتروموتور (۱۱۲M۶) ۲.۲-۱۰۰۰ ۵۴۴ ۲۲۰/۳۸۰ B۵

فلنج B۵

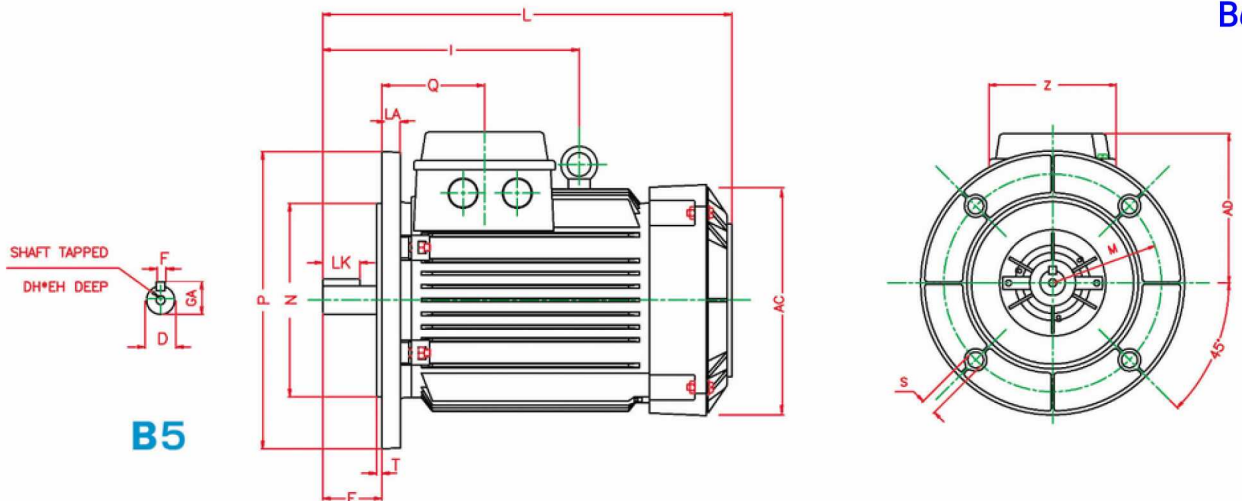

B	BA	K	KB	AB	A	AA	HA	AC	Z	Q	I	L	E	EH	DH	GA	LK	F	D
-	-	-	-	-	-	-	-	217	96	76.5	200	384	60	22	M10	31	40	8	28

X	FLANGE SYM (DIN)	FLANGE SYM (IEC)	T	S	P	N	M	LA	AD	HD	H	C
	A250	FF215	4	15	250	180	215	12	144	-	-	-